



2014

Spare Parts/ Ersatzteile/ Reservdelar/ Varaosat

Silomatic 320/420 ACI & 1210/1410 ACI Serie 10.2 - 10.4
(Lykkecontroller)



981004
GB/SE/FI

Oy Elho Ab
68910 BENNÄS

FINLAND

Phone: +358 6 7888000

Fax: +358 6 78880048

E-mail:elho@elho.fi

ELHO MULTICABLE CONTROLLER AC / ACI

320 - 620

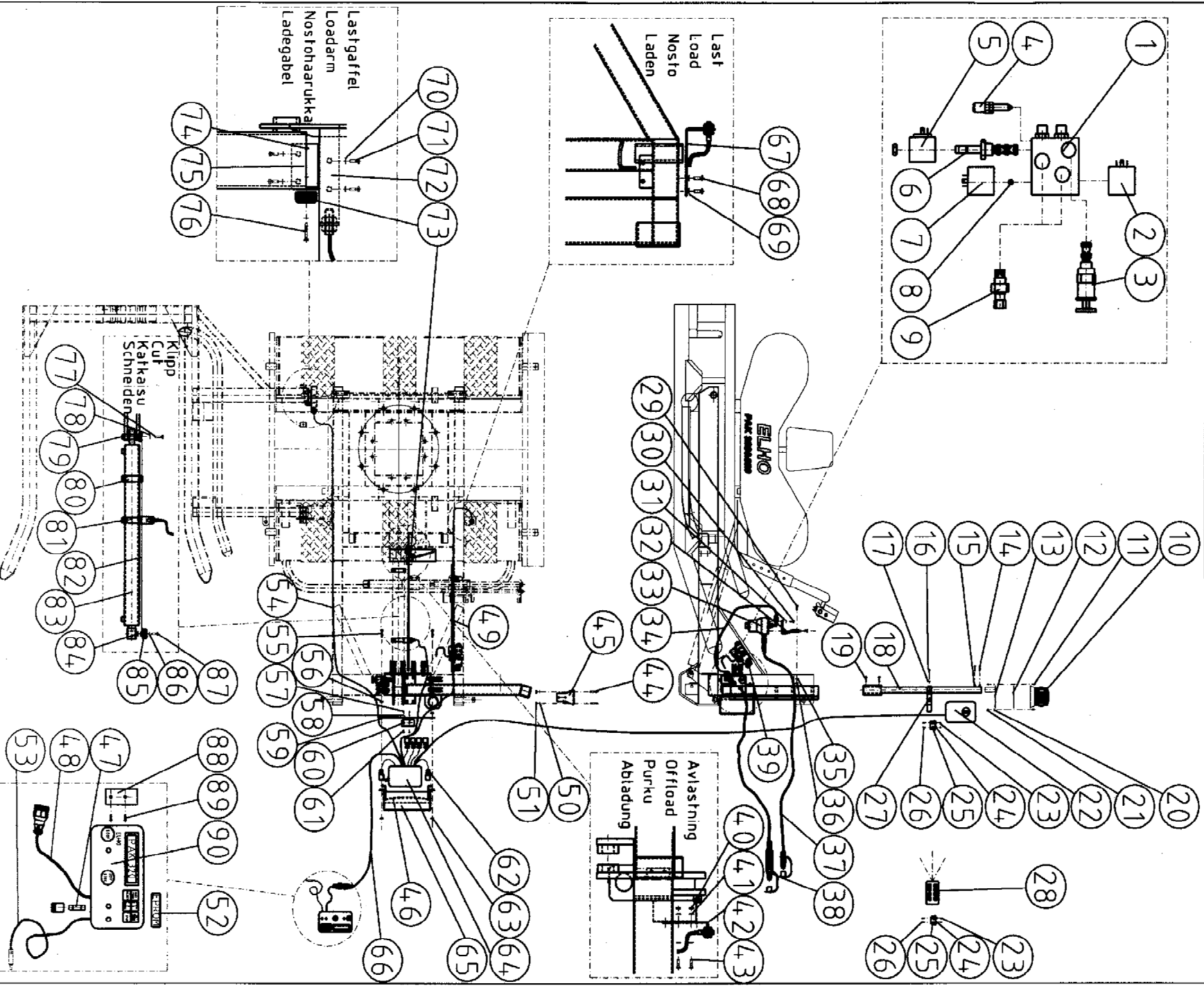

Pos	Benämning	Name	Nimi	No	Pcs	
		ELHO MULTICABLE CONTROLLER 320-620 AC / ACI				
1	Vent block 4-port (komp) 520	Valve block 4-port (compl) 520	Venttiilipöytä 4-portti (täyd) 520	807880	1	
	Vent block 3-port (komp) 320	Valve block 3-port (compl) 320	Venttiilipöytä 3-portti (täyd) 320	807881	1	
2	Styrventil (komp Vickers)	Tuningvalve (compl Vickers)	Säätöventtiili (täyd Vickers)	807882	1	
	DGV4-3 8C VM U G7 60	DGV4-3 8C VM U G7 60	DGV4-3 8C VM U G7 60			
	Solenoid G5078847 12V 30W	Solenoid G5078847 12V 30W	Solenoid G5078847 12V 30W	807883	1	
3	Flödesinställning Vickers	Flowcontrol valve Vickers	Virtaussäätö Vickers	807561	1	
	PFR 2-10-S-0/5.00	PFR 2-10-S-0/5.00	PFR 2-10-S-0/5.00			
4	Ställskruv (John Deere)	Adjusting screw (John Deere)	Säätöruuvi (John Deere)	807580	1	
5	Solenoid Vickers	Solenoid Vickers	Solenoid Vickers	807590	3(4)	
	SV2-10-0-4-12 DC	SV2-10-0-4-12 DC	SV2-10-0-4-12 DC			
6	Ventilpatron Vickers SV2 -10-0-4-12 DG	Cartridge valve Vickers SV2-10-0-4-12 DG	Venttiilipatruuna Vickers SV2-10-0-4-12 DG	807600	3(4)	
	Tätningserie till 807600	Seal kit for 80760	Tiivistesarja 807600, seen	807602		
7	Bromsventil (komplett Vickers)	Break valve (compl Vickers)	Jarru venttiili (täyd Vickers)	807860	1	
	DGV4-3 2A MU G7 60	DGV4-3 2A MU G7 60	DGV4-3 2A MU G7 60			
	Solenoid G5078847 12V DC30W	Solenoid G5078847 12V DC30W	Solenoid G5078847 12V DC30W	807883	1	
8	Strypning (port A) Ø 0,8	Throttle (port A) Ø 0,8	Kuristus (port A) Ø 0,8	807859	1	
9	Chockv. Vickers RV-6-10-C-0-25 80 bar	Shockvalve Vickers RV6-10-C-0-25 80 bar	Sokkiventtiili Vickers RV6-10-C-25 80 bar	807570	2	
	Tätningserie till 807570	Sealkit for 807570	Tiivistesarja 807570	807572		
10	Rotorlampa	Rotorlamp	Varoituslamppu	822190	1	
11	Spårskruv M5x12	Slot-headed screw M5x12	Uraruuvi M5x12	132455	1	
12	Packning	Seal	Tiiviste	822192	1	
13	Rotorlampplåt	Rotorlampplate	Varoituslampun pelti	822038	1	
14	Sexkantskruv M6x35	Bolt M6x35	Kuusioruuvi M6x35	130680	2	
15	Mutter M6 DIN 980	Nut M6 DIN 980	Mutteri M6 DIN 980	131390	2	
16	Sexkantskruv M6x35	Bolt M6x35	Kuusioruuvi M6x35	130680	1	
17	Mutter M6 DIN 980	Nut M6 DIN 980	Mutteri M6 DIN 980	131390	2	
18	Fästtorn	Mounting pipe	Kiinnityspotki	807815	1	
19	Sexkantskruv M8x30	Bolt M8x30	Kuusioruuvi M8x30	130770	2	
20	Bricka M5 DIN 125 A	Washer M5 DIN 125 A	Aluslevy M5 DIN 125 A	131710	2	
21	Mutter M5 DIN 985	Nut M5 DIN 985	Mutteri M5 DIN 985	131550	2	
22	Mottagare ACI	IC-Receiver	Vastaanottaja ACI	819630	1	
23	Mutter M4 DIN 985	Nut M4 DIN 985	Mutteri M4 DIN 985	131540	2	
24	Bricka M4 DIN 125A	Washer M4 DIN 125A	Aluslevy M4 DIN 125A	131708	2	
25	Fäste	Bracket	Pidike	819640	2	
26	Sänkt spårskruv M4x20 DIN 963	Shelled slotscrew M4x20 DIN 963	Uppo uraruuvi M4x20 DIN 963	132478	2	

Pos	Benämning	Name	Nimi	No	Pcs
		ELHO MULTICABLE CONTROLLER 320-620 AC / ACI			
26	Sänkt spårskruv M4x20 DIN 963	Shelled slotscrew M4x20 DIN 963	Uppo uraruuvi M4x20 DIN 963	132478	2
27	Mottagarfäste ACI	Bracket ACI	Pidike ACI	807819	1
28	Fjärrkontroll ACI	Remote control ACI	Kaukosäädin ACI	819650	1
29	Sexkantskruv M12x30	Bolt M12x30	Kuusioruuvi M12x30	130971	1
30	Sexkantskruv M8x20	Bolt M8x20	Kuusioruuvi M8x20	130720	2
31	Bricka M8 DIN 125A	Washer M8 DIN 125A	Aluslevy M8 DIN 125A	131750	2
32	Oljefilterfäste	Oilfilterbracket	Öljysuodatin pidike	807813	1
33	Oljefilter (komplett)	Oilfilter (complete)	Öljysuodatin (täydellinen)	807868	1
	Filter	Filter cartridge	Suodatin	807884	1
34	Hydraulslang 3/8" l=450 mm	Hose 3/8" l=450 mm	Hyd letku 3/8" p=450 mm	806510	1
35	Bricka M12 DIN 125A	Washer M12 DIN 125A	Aluslevy M12 DIN 125A	131790	1
36	Mutter M12 DIN 985	Nut M12 DIN 985	Mutteri M12 DIN 985	131600	1
37	Hydraulslang 3/8" l=2600 mm	Hose 3/8" l=2600 mm	Hyd letku 3/8" p=2600 mm	805505	1
38	Hydraulslang 1/2" l=2600 mm	Hose 1/2" l=2600 mm	Hyd letku 1/2" p=2600 mm	145070	1
39	JD ventilet, extrautrustning	Optional JD valve kit	JD venttiili, lisävaruste	807990	1
40	Mutter M6 DIN 985	Nut M6 DIN 985	Mutteri M6 DIN 985	131560	2
41	Bricka M6 DIN 125A	Washer M6 DIN 125A	Aluslevy M6 DIN 125A	131730	2
42	Sensorfäste, avlastning	Sensorbracket, tip	Sensorin pidike, purku	807100	1
43	Sexkantskruv M6x16	Bolt M6x16	Kuusioruuvi M6x16	130620	2
44	Sexkantskruv M8x20	Bolt M8x20	Kuusioruuvi M8x20	130720	2
45	Monitorfästplåt	Monitorbracket	Monitorin pidike	808435	1
46	Databoxhållare	Computerbox bracket	Tietokonelaatikon pidike	819693	1
47	Säkring 16A Ø5x20	Fuse 16A Ø5x20	Sulake 16A Ø5x20	142030	1
48	24-polig kabel, AMP1, l=400	24-pole cable, AMP1, l=400	24-nap kaapeli, AMP1, l=400	819660	1
49	Skyddsror Lastsensor-ram	Protection tube	Suojausputki	807839	1
50	Bricka M8 DIN 125A	Washer M8 DIN 125A	Aluslevy M8 DIN 125A	131750	2
51	Mutter M8 DIN 985	Nut M8 DIN 985	Mutteri M8 DIN 985	131570	2
52	Eprom	Eprom	Eprom	819620	1
53	2-polig elkabel l=5300	2-pole elcable l=5300	2-nap sähkökaapeli l=5300	819680	1
54	Sensor, kabel l=4500	Sensor, cable l=4500	Tunnistin, kaapeli p=4500	822040	3(4)
55	Sexkantskruv M8x40	Bolt M8x40	Kuusioruuvi M8x40	130810	2
56	Mutter M8 DIN 980	Nut M8 DIN 980	Mutteri M8 DIN 980	131395	2
57	Mutter M5 DIN 985	Nut M5 DIN 985	Mutteri M5 DIN 985	131550	2
58	Bricka M5 DIN 125A	Washer M5 DIN 125A	Aluslevy M5 DIN 125A	131710	2
59	Skyddslådsbotten	Protecting plate	Suojauslevy	819695	1

ELHO MULTICABLE CONTROLLER AC / ACI

320 - 620

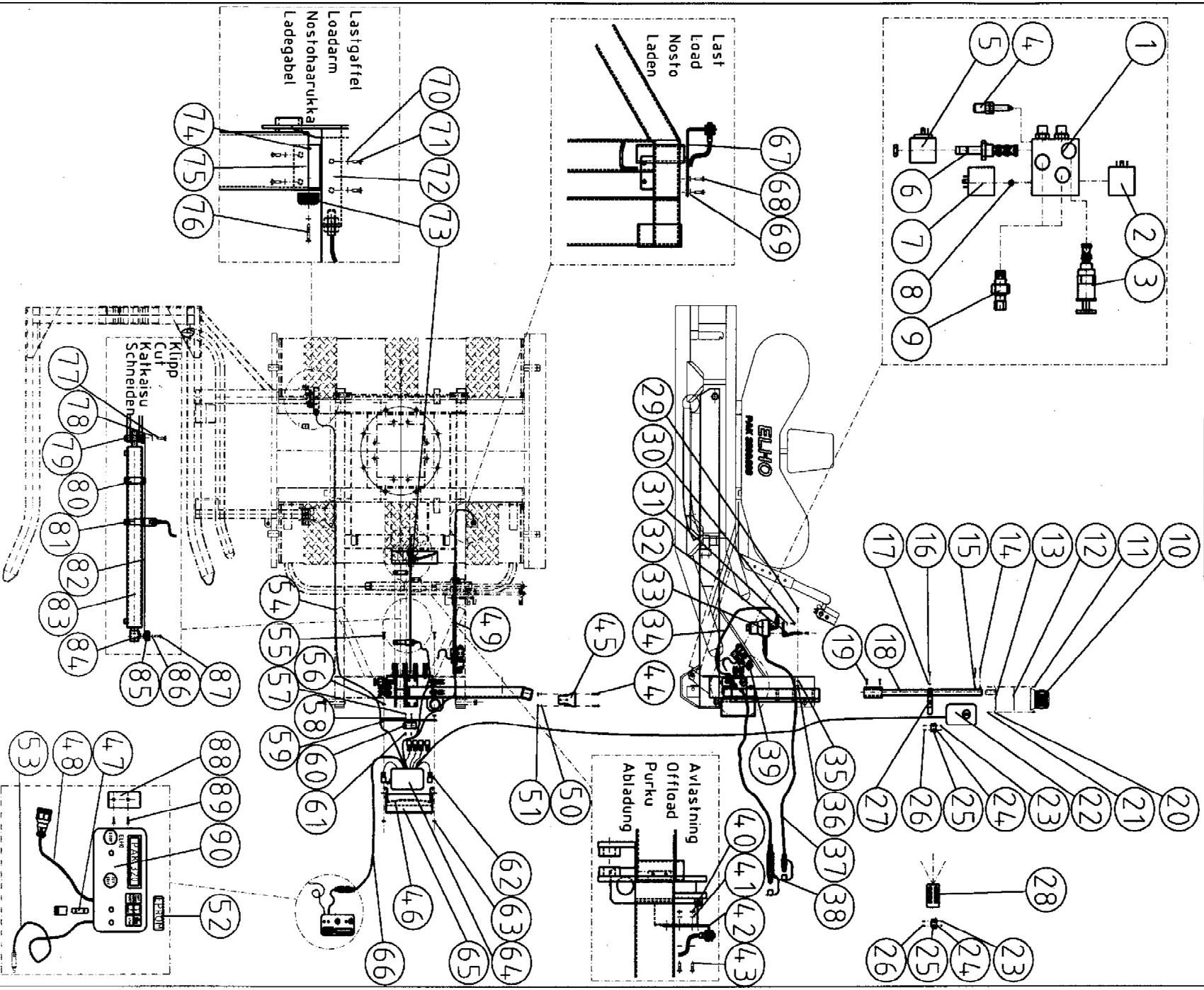

Pos	Benämning	Name	Nimi	No	Pcs
		ELHO MULTICABLE CONTROLLER 320-620 AC / ACI			
60	Fäste, databox	Bracket, computerbox	Pidike, tietokammio	822115	1
61	Sänkt spårskruv M5x20 DIN 963	Shelled slotscrew M5x20 DIN 963	Uppo uraruuvi M5x20 DIN 963	132492	2
62	Ventilbordsstöpsel	Solenoid valve plug	Venttiilin pistoke	822114	6
63	Mutter M8 DIN 985	Nut M8 DIN 985	Mutteri M8 DIN 985	131570	2
64	Databox, (komplett)	Computerbox, (complete)	Tietoboxi, (täydellinen)	819610	1
65	Skyddslåda	Protection box	Suojaus laatikko	819690	1
66	24-polig kabel, AMP2, l=4500	24-pole cable, AMP2, l=4500	24-nap kaapeli, AMP2, l=4500	819670	1
67	Sensorfäste, bord - last	Sensorbracket, table - load	Anturin pidike, pöytä - nosto	807940	1
68	Bricka M6 DIN 125A	Washer M6 DIN 125A	Aluslevy M6 DIN 125A	131730	2
69	Sexkantskruv M6x20	Bolt M6x20	Kuusioruuvi M6x20	130640	2
70	Bricka M6 DIN 125A	Washer M6 DIN 125A	Aluslevy M6 DIN 125A	131730	6
71	Sexkantskruv M6x16	Bolt M6x16	Kuusioruuvi M6x16	130620	4
72	Sensorfäste 520/620	Sensorbracket 520/620	Anturin pidike 520/620	807101	1
73	Magnet Ø20x4,3x10	Magnet Ø20x4,3x10	Magneetti Ø20x4,3x10	805878	1
74	Mutter M6 DIN 985	Nut M6 DIN 985	Mutteri M6 DIN 985	131560	1
75	Magnetfäste - gaffel 520/620	Magnet bracket, loadarm 520/620	Mag. pidike nosto haa. 520/620	807841	1
76	Sexkantskruv M6x25	Bolt M6x25	Kuusioruuvi M6x25	130660	1
77	Sexkantskruv M8x30	Bolt M8x30	Kuusioruuvi M8x30	130760	1
78	Bricka M8 DIN 125A	Washer M8 DIN 125A	Aluslevy M8 DIN 125A	131750	1
79	Övre cylindertapp	Upper cylinder pin	Sylinterin ylätapppi	807834	1
80	Styrning	Guide	Ohjaus	807833	1
81	Sensorfäste, klipp	Sensorbracket, cut	Anturin pidike, katkaisu	807832	1
82	Magnetfäste, klipp	Magnet bracket, cut	Magneetin pidike, katkaisu	807843	1
83	Tippcylinder	Tipcylinder	Kippisylinteri	800070	1
	Tätningsserie	Seal kit	Tiivistesarja	800078	1
84	Mutter M6 DIN 985	Nut M6 DIN 985	Mutteri M6 DIN 985	131560	1
85	Magnet Ø20x4,3x10	Magnet Ø20x4,3x10	Magneetti Ø20x4,3x10	805878	1
86	Bricka M6 DIN 125A	Washer M6 DIN 125A	Aluslevy M6 DIN 125A	131730	1
87	Sexkantskruv M6x25	Bolt M6x25	Kuusioruuvi M6x25	130660	1
88	Fäste, monitor	Bracket, monitor	Pidike, monitori	822115	1
89	Sänkt spårskruv M5x20 DIN 963	Shelled slotscrew M5x20 DIN 963	Uppo uraruuvi M5x20 DIN 963	132492	2
90	Monitor, (komplett)	Monitor, (complete)	Monitori, (täydellinen)	819600	1

ELHO MULTICABLE CONTROLLER AC / ACI

1010 - 1410

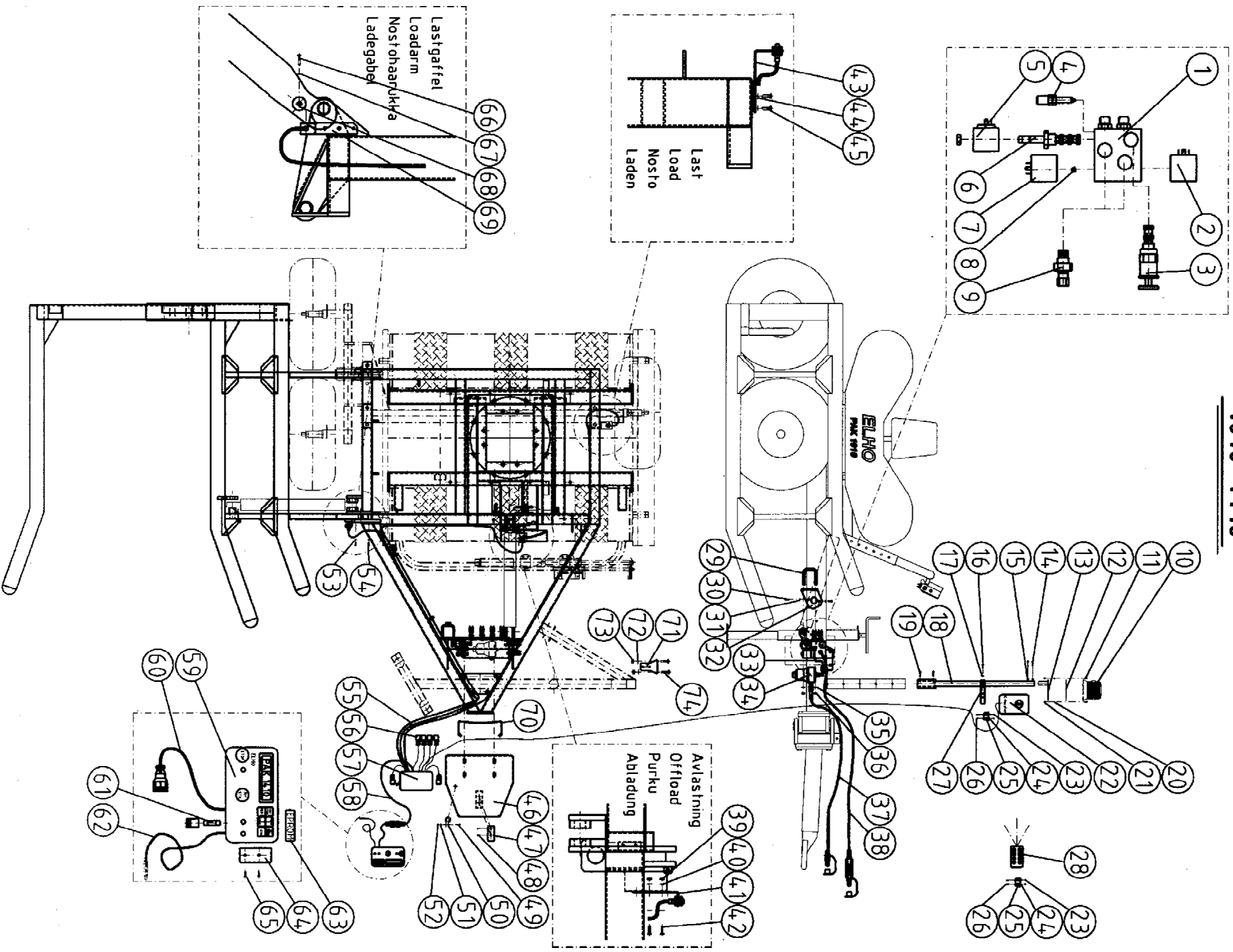

Pos	Benämning	Name	Nimi	No	Pcs
		ELHO MULTICABLE CONTROLLER 1010 - 1410 AC / ACI			
1	Vent block 4-port (komp)	Valve block 4-port (compl)	Venttiilipöytä 4-portti (täyd)	807880	1
2	Styrventil (komp Vickers)	Tuningvalve (compl Vickers)	Säätöventtiili (täyd Vickers)	807882	1
	DGV4-3 8C VM U G7 60	DGV4-3 8C VM U G7 60	DGV4-3 8C VM U G7 60		
	Solenoid G5078847 12V 30W	Solenoid G5078847 12V 30W	Solenoid G5078847 12V 30W	807883	1
3	Flödesinställning Vickers	Flowsetting Vickers	Virtaussäätö Vickers	807561	1
	PFR 2-10-S-0/5.00	PFR 2-10-S-0/5.00	PFR 2-10-S-0/5.00		
4	Ställskruv (John Deere)	Adjusting screw (John Deere)	Säätöruuvi (John Deere)	807580	1
5	Solenoid Vickers	Solenoid Vickers	Solenoid Vickers	807590	4
	SV2-10-0-4-12 DC	SV2-10-0-4-12 DC	SV2-10-0-4-12 DC		
6	Ventilpatron SV2-10-0-4-12 DG	Valve cartridge SV2-10-0-4-12 DG	Venttiilipatruuna SV2-10-0-4-12 DG	807600	4
	Tätningsserie till 807600	Seal kit for 807600	Tiivistesarja 807600, seen	807602	
7	Bromsventil (komplett Vickers)	Break valve (compl Vickers)	Jarru venttiili (täyd Vickers)	807860	1
	DGV4-3 2A MU G7 60	DGV4-3 2A MU G7 60	DGV4-3 2A MU G7 60		
8	Strypning (port A) Ø 0,8	Throttle (port A) Ø 0,8	Kuristus (port A) Ø 0,8	807859	1
9	Chockv. Vickers RV6-10-C-0-50 80 bar	Shockvalve Vickers RV6-10-C-0-50 80 bar	Sokkiventtiili Vickers RV6-10-C-0-50 80 bar	807570	2
	Tätningsserie till 807570	Seal kit for 807570	Tiivistesarja 807570	807572	
10	Rotorlampa	Rotorlamp	Varoituslamppu	822190	1
11	Spårskruv M5x12	Slot-headed screw M5x12	Uraruuvi M5x12	132455	1
12	Packning	Seal	Tiiviste	822192	1
13	Rotorlamplåt	Rotorlampplate	Varoituslampun pelti	822038	1
14	Sexkantskruv M6x35	Bolt M6x35	Kuusioruuvi M6x35	130680	2
15	Mutter M6 DIN 980	Nut M6 DIN 980	Mutteri M6 DIN 980	131390	2
16	Sexkantskruv M6x35	Bolt M6x35	Kuusioruuvi M6x35	130680	1
17	Mutter M6 DIN 980	Nut M6 DIN 980	Mutteri M6 DIN 980	131390	2
18	Fästtorn	Mounting pipe	Kiinnityspotki	807815	1
19	Sexkantskruv M8x30	Bolt M8x30	Kuusioruuvi M8x30	130770	2
20	Bricka M5 DIN 125 A	Washer M5 DIN 125 A	Aluslevy M5 DIN 125 A	131710	2
21	Mutter M5 DIN 985	Nut M5 DIN 985	Mutteri M5 DIN 985	131550	2
22	Mottagare ACI	IC-Receiver	Vastaanottaja ACI	819630	1
23	Mutter M4 DIN 985	Nut M4 DIN 985	Mutteri M4 DIN 985	131540	2
24	Bricka M4 DIN 125A	Washer M4 DIN 125A	Aluslevy M4 DIN 125A	131708	2
25	Fäste	Bracket	Pidike	819640	2
26	Sänkt spårskruv M4x20 DIN 963	Shelled slotscrew M4x20 DIN 963	Uppo uraruuvi M4x20 DIN 963	132478	2
27	Mottagarfäste ACI	Bracket ACI	Pidike ACI	807819	1
28	Fjärrkontroll ACI	Remote control ACI	Kaukosäädin ACI	819650	1
29	Fästbygel	U-bolt	U-pultti	807846	1
30	Sexkantskruv M8x20	Bolt M8x20	Kuusioruuvi M8x20	130720	2
31	Bricka M8 DIN 125A	Washer M8 DIN 125A	Aluslevy M8 DIN 125A	131750	2
32	Oljefilterfäste	Oilfilterbracket	Öljysuodatin pidike	807845	1
33	Hydraulslang 3/8" l=450 mm	Hose 3/8" l=450 mm	Hyd letku 3/8" p=450 mm	806510	1
34	Oljefilter (komplett)	Oilfilter (complete)	Öljysuodatin (täydellinen)	807868	1
	Filter	Filter cartridge	Suodatin	807884	1
35	Bricka M8 DIN 125A	Washer M8 DIN 125A	Aluslevy M8 DIN 125A	131750	2

ELHO MULTICABLE CONTROLLER AC / ACI

1010 - 14.10

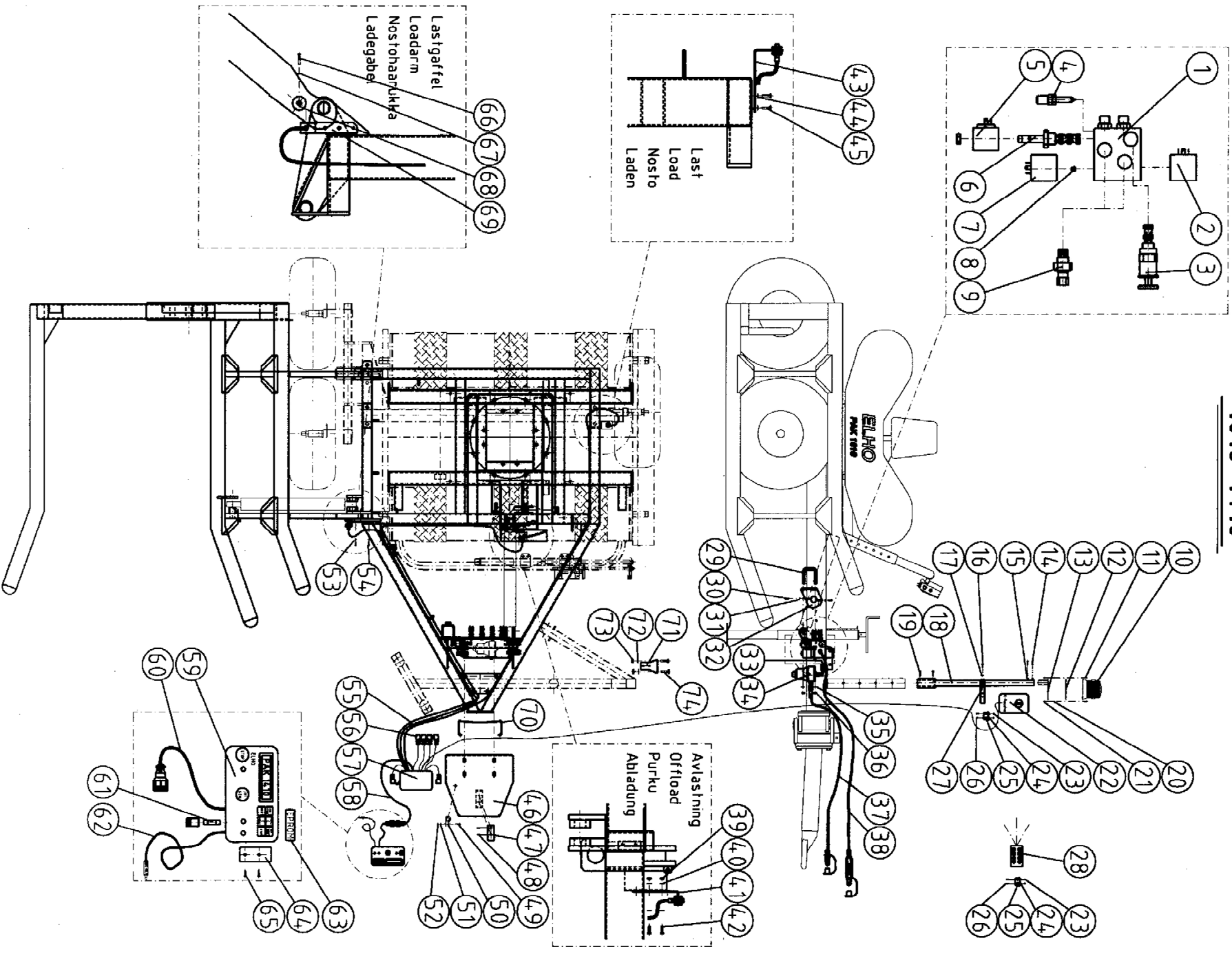

Pos	Benämning	Name	Nimi	No	Pcs
		ELHO MULTICABLE CONTROLLER 1010 - 1410 AC / ACI			
36	Mutter M8 DIN 985	Nut M8 DIN 985	Mutteri M8 DIN 985	131570	2
37	Hydraulslang 3/8" l=2600 mm	Hose 3/8" l=2600 mm	Hyd letku 3/8" p=2600 mm	805505	1
38	Hydraulslang 1/2" l=2600 mm	Hose 1/2" l=2600 mm	Hyd letku 1/2" p=2600 mm	145070	1
39	Mutter M6 DIN 985	Nut M6 DIN 985	Mutteri M6 DIN 985	131560	2
40	Bricka M6 DIN 125A	Washer M6 DIN 125A	Aluslevy M6 DIN 125A	131730	2
41	Sensorfäste, avlastning	Sensorbracket, tip	Sensorin pidike, purku	807100	1
42	Sexkantskruv M6x16	Bolt M6x16	Kuusioruuvi M6x16	130620	2
43	Sensorfäste, bord - last	Sensorbracket, table - load	Sensorin pidike, pöytä - nosto	807940	1
44	Bricka M6 DIN 125A	Washer M6 DIN 125A	Aluslevy M6 DIN 125A	131730	2
45	Sexkantskruv M6x20	Bolt M6x20	Kuusioruuvi M6x20	130640	2
46	Ventilbordsfäste	Valvboardbracket	Venttiilipöydän pidike	807967	1
47	Fäste, databox	Bracket, computerbox	Pidike, tietokammio	822115	1
48	Sänkt spårskruv M5x20 DIN 963	Shelled slotscrew M5x20 DIN 963	Uppo uraruuvi M5x20 DIN 963	132492	2
49	Sexkantskruv M6x20	Bolt M6x20	Kuusioruuvi M6x20	130640	1
50	Monteringsband, 03-LEP-16	Mountingband 03-LEP-16	Asennusnauha 03-LEP-16	147050	1
51	Bricka M6 DIN 125A	Washer M6 DIN 125A	Aluslevy M6 DIN 125A	131730	1
52	Mutter M6 DIN 985	Nut M6 DIN 985	Mutteri M6 DIN 985	131560	1
53	Bricka M6 DIN 125A	Washer M6 DIN 125A	Aluslevy M6 DIN 125A	131730	2
54	Sexkantskruv M6x16	Bolt M6x16	Kuusioruuvi M6x16	130620	2
55	Sensor, kabel l=4500	Sensor, cable l=4500	Tunnistin, kaapeli p=4500	822040	3
56	Ventilbordsstöpsel	Solenoid valve plug	Venttiilin pistoke	822114	6
57	Databox, (komplett)	Computerbox, (complete)	Tietoboxi, (täydellinen)	819610	1
58	24-polig kabel, AMP2, l=4500	24-pole cable, AMP2, l=4500	24-nap kaapeli, AMP2, l=4500	819670	1
59	Monitor, (komplett)	Monitor, (complete)	Monitori, (täydellinen)	819600	1
60	24-polig kabel, AMP1, l=400	24-pole cable, AMP1, l=400	24-nap kaapeli, AMP1, l=400	819660	1
61	Säkring 16A Ø5x20	Fuse 16A Ø5x20	Sulake 16A Ø5x20	142030	1
62	2-polig elkabel l=5300	2-pole elcable l=5300	2-nap sähkökaapeli l=5300	819680	1
63	Eprom	Eprom	Eprom	819620	1
64	Fäste, monitor	Bracket, monitor	Pidike, monitori	822115	1
65	Sänkt spårskruv M5x20 DIN 963	Shelled slotscrew M5x20 DIN 963	Uppo uraruuvi M5x20 DIN 963	132492	2
66	Sexkantskruv M6x25	Bolt M6x25	Kuusioruuvi M6x25	130660	1
67	Bricka M6 DIN 125A	Washer M6 DIN 125A	Aluslevy M6 DIN 125A	131730	1
68	Magnet Ø20x4,3x10	Magnet Ø20x4,3x10	Magneetti Ø20x4,3x10	805878	2
69	Sensorfäste, lastgaffel	Sensorbracket, loadarm	Anturin pidike, nosthaarukka	807925	1
70	Databoxhållare	Computerbox bracket	Tietokonelaatikkon pidike	819692	1
71	Monitorfästplåt	Monitor bracket	Monitorin pidike	808435	1
72	Bricka M8 DIN 125A	Washer M8 DIN 125A	Aluslevy M8 DIN 125A	131750	2
73	Mutter M8 DIN 985	Nut M8 DIN 985	Mutteri M8 DIN 985	131570	2
74	Sexkantskruv M8x20	Bolt M8x20	Kuusioruuvi M8x20	130720	2